

Catene per il sollevamento VIS Gr.10

Lifting chains VIS Gr.10

Correntes VIS G10

Cadenas de elevación VIS Gr.10

VIS 400

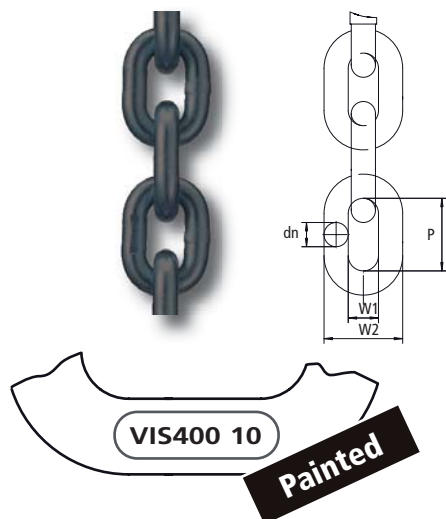

EN 818-2 + 25% of load - 40°C ÷ 400°C

Articolo Article	Catena Chain	Lunghezza ⁽¹⁾ Length ⁽¹⁾	Dimensioni Dimension			WLL	BF	Peso Weight Approx
			p	W1 (min)	W2 (max)			
	dn mm	m	mm	mm	mm	kg	kN	kg/m
VIS400-6	6	100	18	7,8	22,2	1.400	56,5	0,87
VIS400-7	7	100	21	9,1	25,9	1.900	77	1,21
VIS400-8	8	100	24	10,4	29,6	2.500	101	1,56
VIS400-10	10	100	30	13	37	4.000	157	2,41
VIS400-13	13	50	39	16,9	48,1	6.700	265	4,12
VIS400-16	16	50	48	20,8	59,2	10.000	402	6,04
VIS400-19	19	25	57	24,7	70,3	14.000	567	8,71
VIS400-22	22	25	66	28,6	81,4	19.000	760	11,40

VIS 200

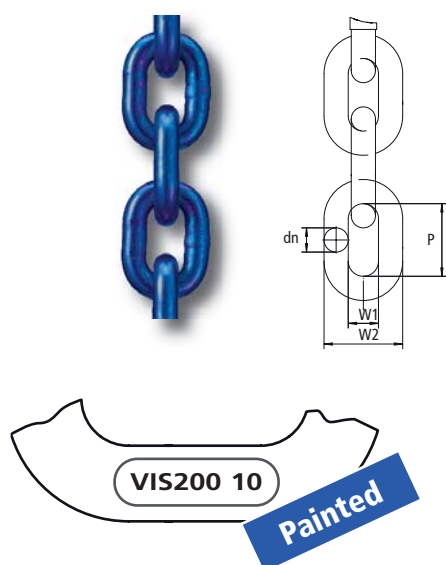

EN 818-2 + 25% of load - 29°C ÷ 205°C

Articolo Article	Catena Chain	Lunghezza ⁽¹⁾ Length ⁽¹⁾	Dimensioni Dimension			WLL	BF	Peso Weight Approx
			p	W1 (min)	W2 (max)			
	dn mm	m	mm	mm	mm	kg	kN	kg/m
VIS200-6	6	100	18	7,8	22,2	1.400	56,5	0,83
VIS200-7	7	100	21	9,1	25,9	1.900	77	1,17
VIS200-8	8	100	24	10,4	29,6	2.500	101	1,51
VIS200-10	10	100	30	13	37	4.000	157	2,40
VIS200-13	13	50	39	16,9	48,1	6.700	265	4,00
VIS200-16	16	50	48	20,8	59,2	10.000	402	6,00
VIS200-19	19	25	57	24,7	70,3	14.000	567	8,71
VIS200-22	22	25	66	28,6	81,4	19.000	760	11,40

- VIS 200 è certificabile secondo ASTM A973. • VIS 200 can be certified according ASTM A973
- VIS 200 pode ser certificada conforme norma ASTM A973 • VIS 200 puede ser certificada conforme norma ASTM A973.

⁽¹⁾ Lunghezza unitaria di vendita

⁽¹⁾ Packaging unit length